



SECTIONAL OVERHEAD DOORS

a complete range
for every application



www.dynacodoor.com



Dynaco was founded in 1987, dedicated to finding a solution for any damages caused by - and to - high-speed roll-up doors. Inspired by flexible pool covers, Dynaco designed the first ever flexible, self-repairing door, known as the Dynaco Classic.

Later, another innovation followed: Dynaco's revolutionary Push-Pull technology, marketed as the "magic" door. Thanks to this continuous innovative approach and passion, Dynaco is known for producing "the most copied door in the world".

The company distributes doors through a network of professionals only, active in 5 continents.

With its most extensive product range in the industry, Dynaco stays always AHEAD. And always operates with the end-user in mind.

Besides High-Performance Doors, Dynaco offers a complete portfolio of Sectional Overhead Doors.

All Dynaco Sectional Overhead Doors are suited to any type of building or environment, all with regards to function and appearance.

The Dynaco Overhead Sectional Doors were designed to meet all operational and safety requirements in the European Directives and the standards issued by the European Standardisation Committee, CEN.

Why this is the right door for your business?



User safety

Thanks to the balancing system heavy forces are supported. In case of a spring or cable break its counterforce is lost. The door is therefore equipped with safety devices that can block downward door movement.



Electrical operations

All doors can be equipped of the ID07 Operator. With a built in frequency convertor. It provides the advantages of a 230V single phase power supply. Also available in the 2H version: double speed operator, 0,5m/s opening and 0,25m/s closing.



Unique glass technology

Thanks to the 2,5 mm acrylic we create a better appearance of the facade without any reflection.



Made to measure

This door is fully customizable with a large aesthetic choice.



Energy saving

Thanks to the outstanding U value of the doors and the performances of the electrical operator, the Dynaco Sectional doors becomes the best way to maximize temperature control inside the buildings.

Why Dynaco?



Conform to EN norms

All Dynaco doors are completely conform to EN13241-1.



Certified performance

Performance of all Dynaco doors has been tested and certified by a third-party notified body.



Wind resistant

Wider door panels and panels with windows are reinforced with metal profiles that act as trusses.



Rigid and secure

Dynaco sectional overhead doors are ideal to protect your building when closed.

I-14F FRAME I-14P PANEL



The Dynaco I-14 P Panel Overhead Sectional Door, with its modern, sleek design, is one of the most stable and well-insulated overhead doors on the market. The door is made of panels without thermal bridge, to reduce thermal transmittance and consequent energy cost.

The Dynaco I-14 F Frame Overhead Sectional Door is made of aluminium tubular profiles, filled with sandwich panels or acrylic windows. Its high light admission makes this door the ideal choice for working environments that require maximum illumination.

Construction (I-14P)

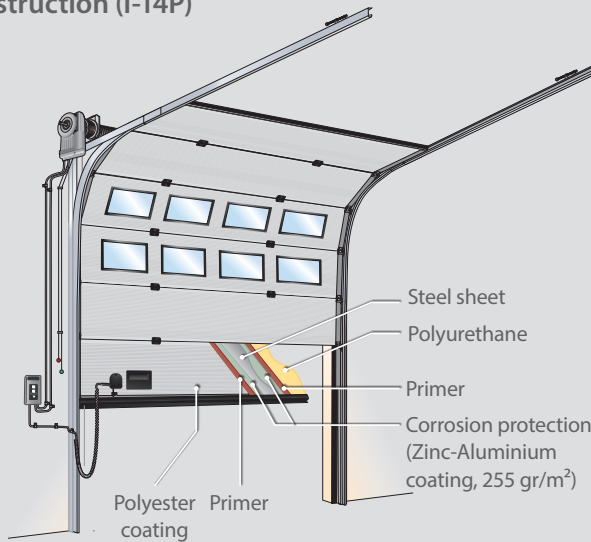

Construction (I-14F)

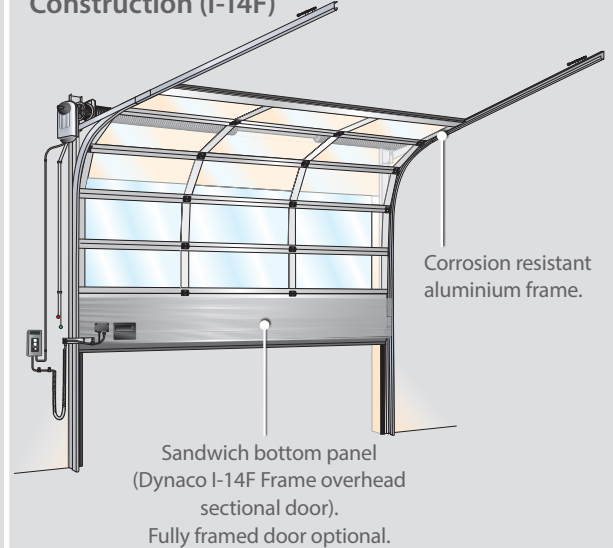

Access and automation options



Assisted manual operation. Two different types of chain hoist are available, depending on door weight.



Standard Dynaco electrical systems: ID07 operator / C700 control system.

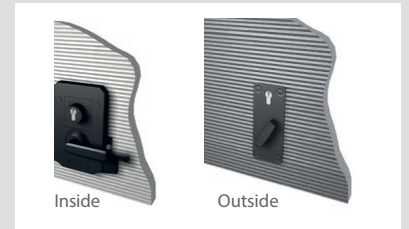

Complete lock including handle and cylinder for both sides or inside only. Any door equipped with an electrical lock can be remotely locked by means of a switch or via a PC.

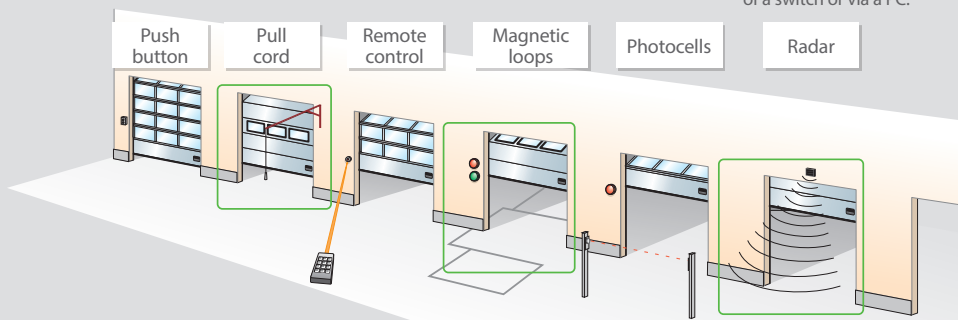

I-14S SPEED I-18P INSULATED



Made of 82mm thick insulated panel, and with broken cold bridge, the Dynaco 18P provides two main advantages: unrevealed energy saving, and maximum temperature control to make your work environment much more comfortable.

Constructed to meet the most stringent environmental regulations, the engineering and features of the Dynaco I-18P exceed current requirements with an exceptionally low U-value of $0,46 \text{ W/m}^2\text{K}^*$.

* for a door reference 5000x5000 without windows.

Dynaco I-14S overhead sectional doors have been designed to increase speed and benefit your business. Speed improves your working environment, increases safety, reduces energy expenses and more.

With an operating speed of approximately one meter per second, the Dynaco I-14S not only saves time but gives it back to you.

Construction (I-18P)

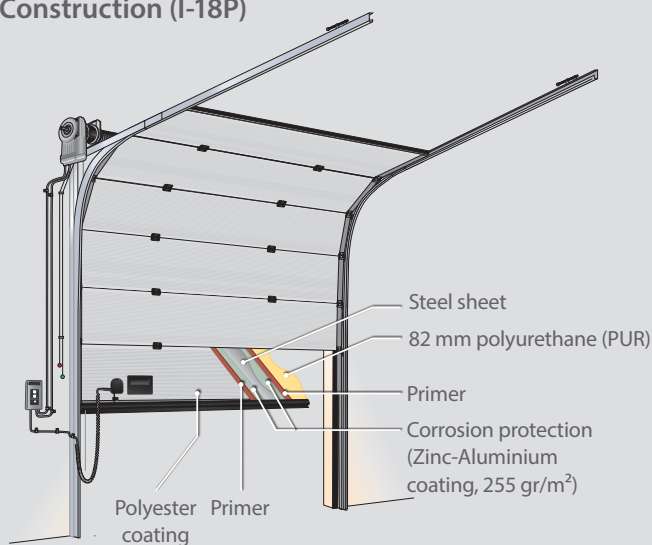

Construction (I-14S)



Technical features



Dynaco I-18P: 82 mm thickness of insulation.

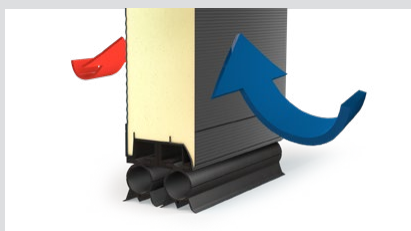

Dynaco I-18P: tight double seal.

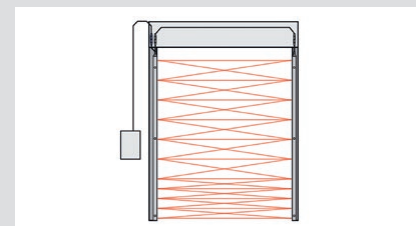
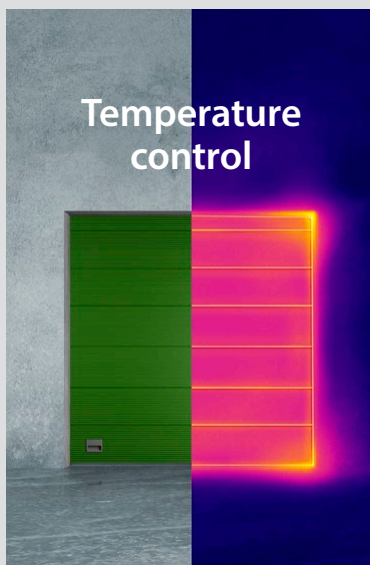

When the door's photo-cell light grid detects an obstacle in the door opening, it stops the door immediately, reducing the risk of accidents and injury.



Dynaco I-14S equipped with IDO75.

I-14FG FULL GLAZED I-14DD DIRECT DRIVE



Dynaco I-14DD have been designed without spring package. The balancing of the door is compensated by a direct drive operator. Low maintenance cost and limited risk of door downtime will profit your business.

The Dynaco I-14DD offers excellent thermal insulation. The door's high-quality performance makes it the ideal choice for applications where the aggressive environment is an issue like for example carwash halls.

The Dynaco I-14FG overhead sectional doors are fully glazed door, designed to be used when there is a need for maximum light, exposure, or vision.

Up to 3300 mm each aluminium frame is glazed with one single pane of hardened glass. Larger doors up to 5500 mm only use two panes of hardened glass.

All in all a state of the art design that fits perfectly in modern buildings and showrooms.

Construction (I-14DD)



Construction (I-14FG)

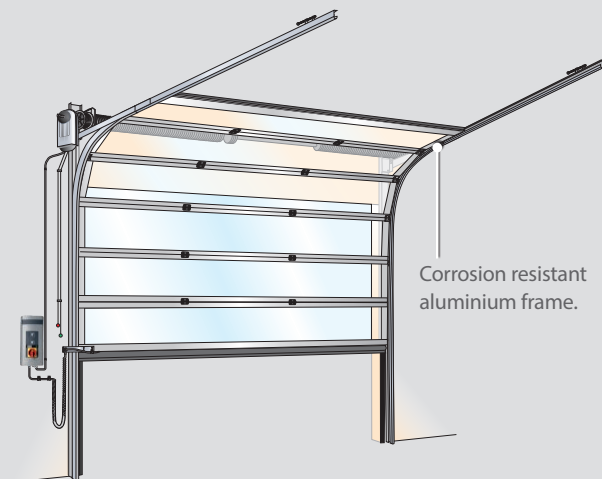

Technical features (I-14DD)

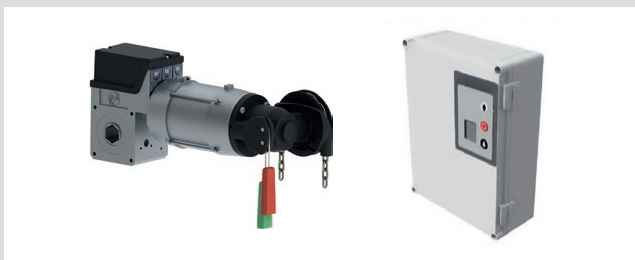

Direct drive and control system.

Technical features (I-14FG)

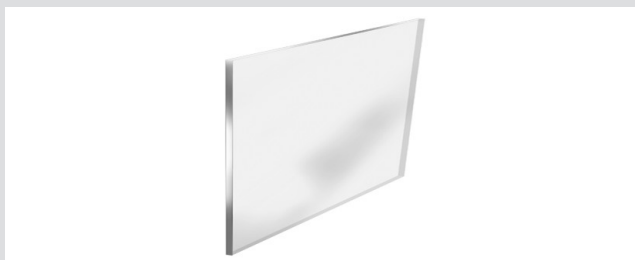

Hardened glass.



Springless system.



Standard Dynaco electrical systems: IDO7 operator / C700 control system.



Dynaco offers a wide range of products for several industrial applications.
Find out more on www.dynacodoor.com.

SECTIONAL OVERHEAD DOORS

Always ahead



Dynaco Europe NV
Waverstraat 21 B-9310 Moorsel-Aalst (Belgium)
Tel. +32 53 72 98 98 info@dynacodoor.com
www.dynacodoor.com

About Dynaco

Dynaco is the world leader in high speed door technology, offering state of the art solutions for both commercial and industrial applications. Founded in 1987, we have extensive expertise in high-performance doors. Yet we continue to invest in exceeding your expectations of quality and performance. Our network of certified and dedicated partners ensures optimal service to all our customers across Europe. Dynaco is a proud member of the ASSA ABLOY Group, the global leader in entrance solutions. As part of its Entrance Systems division, we share the same mission and corporate values: helping billions of people experience a more open world every single day, through solutions for efficient and safe flow of goods and people. These include a wide range of automated pedestrian, industrial and residential doors, loading dock equipment, perimeter fencing and service.